

Radiation by an AC Voltage Source

Kirk T. McDonald

Joseph Henry Laboratories, Princeton University, Princeton, NJ 08544

(January 9, 2005)

1 Problem

An AC voltage source is a two-terminal device that supplies (the real part of) voltage $V_0 e^{i\omega t}$ to a load across its terminals, independent of the details of the load.

Consider an AC voltage source in the absence of any load. The voltage between the terminals is still oscillating, so there are oscillating electric fields present, which implies that there must be some charge in motion. That is, an AC voltage source must support an internal, oscillating current.

Since oscillating currents generate radiation, we infer that an unloaded AC voltage source emits radiation.

- (a) An idealized model of an AC voltage source is shown in the figure below.

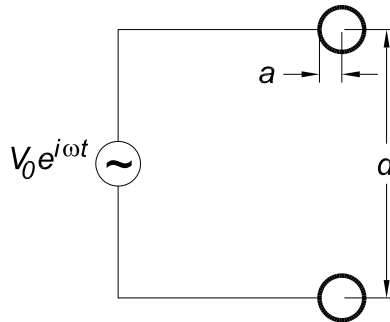

The internal resistance of the source is zero, but a reactance exists due to the capacitor formed by the two terminals, which are taken to be conducting spheres of radii a , separated by a distance $d \ll \lambda$, where $\lambda = 2\pi c/\omega$ and c is the speed of light.

What is the capacitance C of this capacitor, accurate to order a/d ?

- (b) Deduce the radiation resistance R_{rad} of the AC voltage source, which relates the time-average radiated power $\langle P \rangle$ to the peak current $|I_0|$ according to

$$\langle P \rangle = \frac{1}{2} |I_0|^2 R_{\text{rad}}. \quad (1)$$

Ignore the radiation from the wires of the source (which are largely inside a grounded metal box), and consider the radiation as due to time-dependent charges $\pm q$ separated by distance d .

What is the complex impedance $Z = V/I$ of the AC voltage source, which relates the voltage V to the internal current I ?

2 Solution

- (a) The potential V due to charge q on a single conducting sphere of radius a is (in Gaussian units)

$$V(r) = \frac{q}{r}, \quad (r \geq a). \quad (2)$$

The potential difference ΔV between the sphere and a point at distance d from it is

$$\Delta V = \frac{q}{a} - \frac{q}{d} = \frac{q}{a} \left(1 - \frac{a}{d}\right). \quad (3)$$

If a second conducting sphere of radius a is placed at the point d , and carries charge $-q$, the potential difference between the two spheres is, to accuracy a/d , simply twice that of eq. (3),¹

$$\Delta V = \frac{2q}{a} \left(1 - \frac{a}{d}\right). \quad (4)$$

The capacitance C of the capacitor formed by the two spheres is related by $\Delta V = q/C$, so that

$$C = \frac{a}{2(1 - a/d)} = \frac{a}{2} \left(1 + \frac{a}{d}\right), \quad (5)$$

to order a/d .

- (b) We consider the radiator of the AC voltage source to be the electric dipole formed by charges $\pm q(t)$ that are separated by distance d . The dipole moment is $p = qd = q_0 d e^{i\omega t}$, since the charges oscillate at the angular frequency ω of the AC voltage source.

The time-average power $\langle P \rangle$ radiated by this oscillating electric dipole is given by a version of Larmor's formula,

$$\langle P \rangle = \frac{|\ddot{p}|^2}{3c^3}. \quad (6)$$

We first express the derivative \dot{p} in terms of the current I ,

$$\dot{p} = \dot{q}d = Id = I_0 d e^{i\omega t}, \quad (7)$$

where I_0 is a complex number. Then,

$$P = \frac{|I_0|^2 \omega^2 d^2}{3c^3} = \frac{4\pi}{c} \frac{\pi}{3} |I_0|^2 \frac{d^2}{\lambda^2} \equiv \frac{1}{2} |I_0|^2 R_{\text{rad}}. \quad (8)$$

Recalling that $4\pi/c = 377$ Ohm is the "resistance of the vacuum", we identify the radiation resistance R_{rad} of the AC voltage source as

$$R_{\text{rad}} = \frac{4\pi}{c} \frac{2\pi}{3} \frac{d^2}{\lambda^2} = 790 \frac{d^2}{\lambda^2} \Omega. \quad (9)$$

The total impedance Z of the AC voltage source is the sum of the (real) radiation resistance (9) and the (imaginary) capacitive reactance $1/i\omega C$ with C given by eq. (5). Thus,

$$Z = R_{\text{rad}} - \frac{i}{\omega C}. \quad (10)$$

¹A more accurate value could be deduced from sec. 5.082 of [1].

The radiation resistance is small for $d \ll \lambda$, while the reactance,

$$X_C = \frac{1}{\omega C} \approx \frac{4\pi \lambda}{c a} = 377 \frac{\lambda}{a} \Omega, \quad (11)$$

is large. Hence, $Z \approx -i377\lambda/a$ Ohm, so that the internal current of the AC voltage source,

$$I_0 = V_0/Z \approx i \frac{V_0}{377\Omega} \frac{a}{\lambda}, \quad (12)$$

is small.

An equivalent circuit for the AC source is sketched below. Since R is small and X_C is large, these internal impedances can be ignored in applications where radiation is not important.

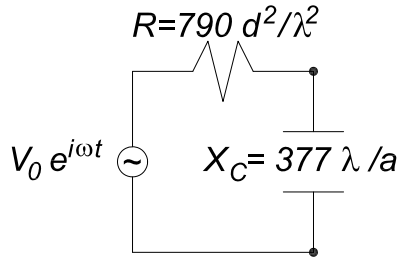

3 Comments

This problem arose from considerations of how an AC voltage source is simulated in numerical computations of antennas, such as the NEC4 program [2].

In these programs, an AC voltage source of strength V_0 is modeled as a current-carrying segment of length d that supports an electric field of magnitude $E = V_0/d$ at its center. From the discussion in parts 1 and 2, we recognize the current to be a simulation of the internal current of the source, which exists even when the source is not connected to anything. The voltage, of course, represents the voltage that would be applied by the source to the terminals located at the two ends of the segment.

NEC4 models consisting of only a single segment, which is an AC voltage source, compute a radiation resistance equal to eq. (9) and a reactance similar, though not quite equal, to eq. (11). In general, an AC voltage source drives a larger antenna structure, which places an additional reactance (and additional radiation resistance) in parallel to the internal reactance of the source. The antenna reactance is typically much smaller than the internal reactance of the source, so that the antenna current is insensitive to the source reactance. It is desirable, however, that the contribution of the AC voltage source to the radiation resistance (which adds in series with the radiation resistance of the antenna) is well modeled, which is the case for the NEC4 program.

4 References

- [1] W.R. Smythe, *Static and Dynamic Electricity*, 3rd ed. (McGraw-Hill, New York, 1968).
- [2] G.J. Burke, *Numerical Electromagnetic Code – NEC4*, UCRL-MA-109338 (January, 1992), <http://www.llnl.gov/eng/ee/erd/ceeta/emnec.html>
<http://puhep1.princeton.edu/~mcdonald/Nec4/Manuals/NEC4TheoryMan.pdf>
<http://puhep1.princeton.edu/~mcdonald/Nec4/Manuals/NEC4UsersMan.pdf>